

PAGE 1/5	ISSUE 1432B	SERIES ECO MMCX	PART NUMBER R110A422830
----------	-------------	-----------------	-------------------------

 Australian Representatives
ROJONE, PTY LTD.
 Tel: 02 9829 1555
 E: sales@rojone.com.au
 www.rojone.com.au

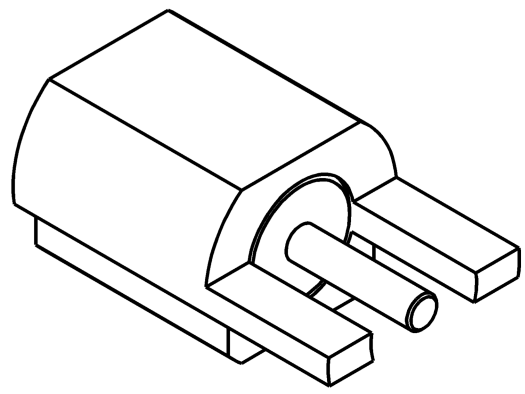

All dimensions are in mm.

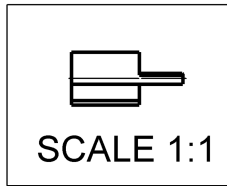
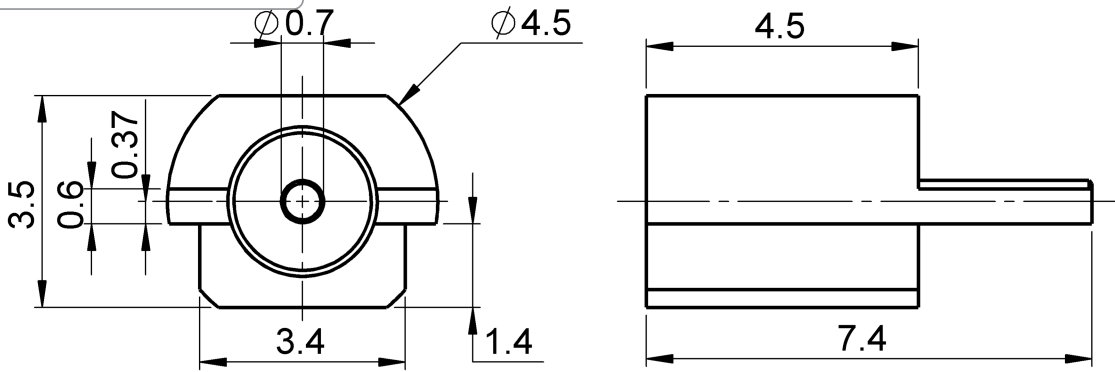
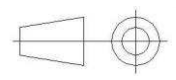

COMPONENTS	MATERIALS	PLATING (µm)
Body	BRASS	GOLD
Center contact	BERYLIUM COPPER	GOLD
Outer contact		
Insulator	PTFE	
Gasket		
Others parts		
-	-	-
-	-	-

PAGE 2/5	ISSUE 1432B	SERIES ECO MMCX	PART NUMBER R110A422830
----------	-------------	------------------------	--------------------------------

PACKAGING

Standard	Unit	Other
1500	Contact us	Contact us

ELECTRICAL CHARACTERISTICS

Impedance		50	Ω
Frequency		0-3	GHz
VSWR	1.35	+	0 x F(GHz) Maxi
Insertion loss		0.1	√F(GHz) dB Maxi
RF leakage		NA	- F(GHz) dB Maxi
Voltage rating		250	Veff Maxi
Dielectric withstanding voltage		500	Veff mini
Insulation resistance		1000	MΩ mini

ENVIRONMENTAL

Operating temperature	-40/+85	°C
Hermetic seal	NA	Atm.cm3/s
Panel leakage	NA	

MECHANICAL CHARACTERISTICS

Center contact retention			
Axial force – Mating End		7	N mini
Axial force – Opposite end		7	N mini
Torque		NA	N.cm mini

SPECIFICATION

OTHER CHARACTERISTICS

Recommended torque			
Mating		NA	N.cm
Panel nut		NA	N.cm

Assembly instruction:

Mating life		100	Cycles mini
Weight		0.35	g

Others:

PAGE 3/5	ISSUE 1432B	SERIES ECO MMCX	PART NUMBER R110A422830
----------	-------------	-----------------	-------------------------

SOLDER PROCEDURE

1. Deposit solder paste 'SnAg4Cu0.5' on mounting zone by screen printing application. We recommend a low residue flux. We advise a thickness of 150 micromm (5.850 microinch). Verify that the edges of the zone are clean.
2. Placement of the receptacle on the mounting zone with an automatic machine of 'pick and place' type. A video camera is recommended for positioning of the component . Adhesive agents must not be used on the receptacle.
3. This process of soldering has been tested with convection oven .Below please find ,the typical profile to use.
4. The cleaning of printed circuit boards is not obliged .

Verification of solder joints and position of the component by visual inspection.

TEMPERATURE PROFILE

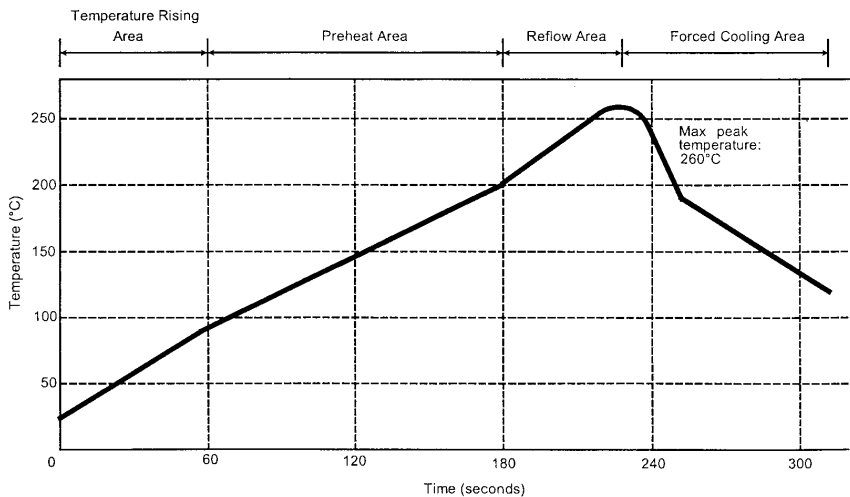

Parameter	Value	Unit
Temperature rising Area	1 - 4	°C/sec
Max Peak Temperature	260	°C
Max dwell time @260°C	10	sec
Min dwell time @235°C	20	sec
Max dwell time @235°C	60	sec
Temperature drop in cooling Area	-1 to - 4	°C/sec
Max dwell time above 100°C	420	sec

PAGE 4/5	ISSUE 1432B	SERIES ECO MMCX	PART NUMBER R110A422830
----------	-------------	-----------------	-------------------------

PCB

PCB PATTERN

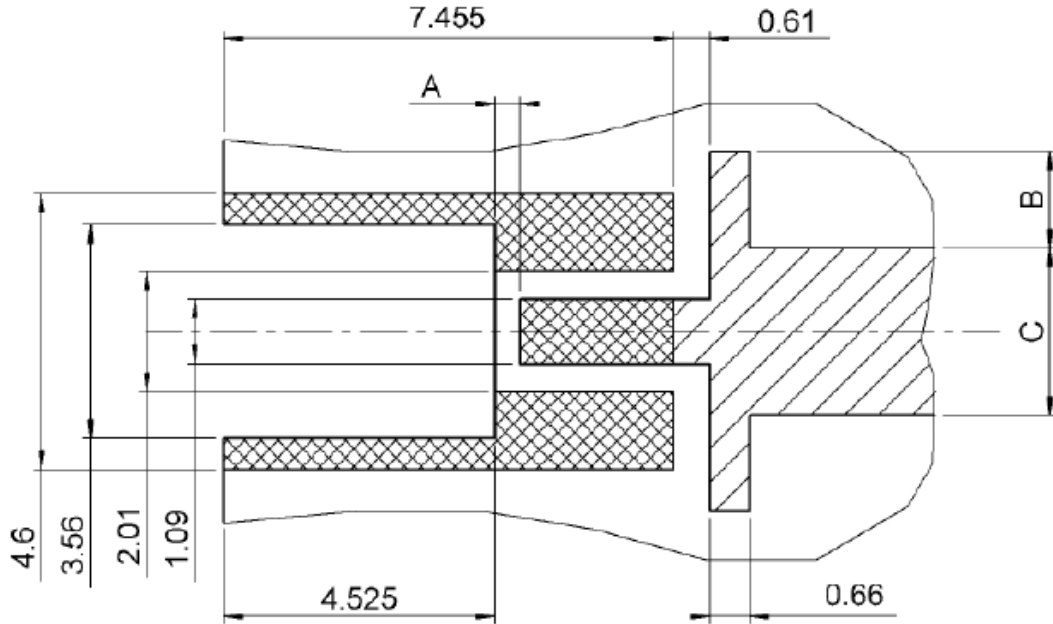

-  PATTERN
-  AREA FOR SOLDER PASTE

PCB THICKNESS	A	B	C
0.79	0.99	-	1.4
0.99	0.89	0.3	1.8
1.6	0.41	1.6	2.79

SHADOW OF MCX PECEPTACLE FOR VIDEO CAMERA

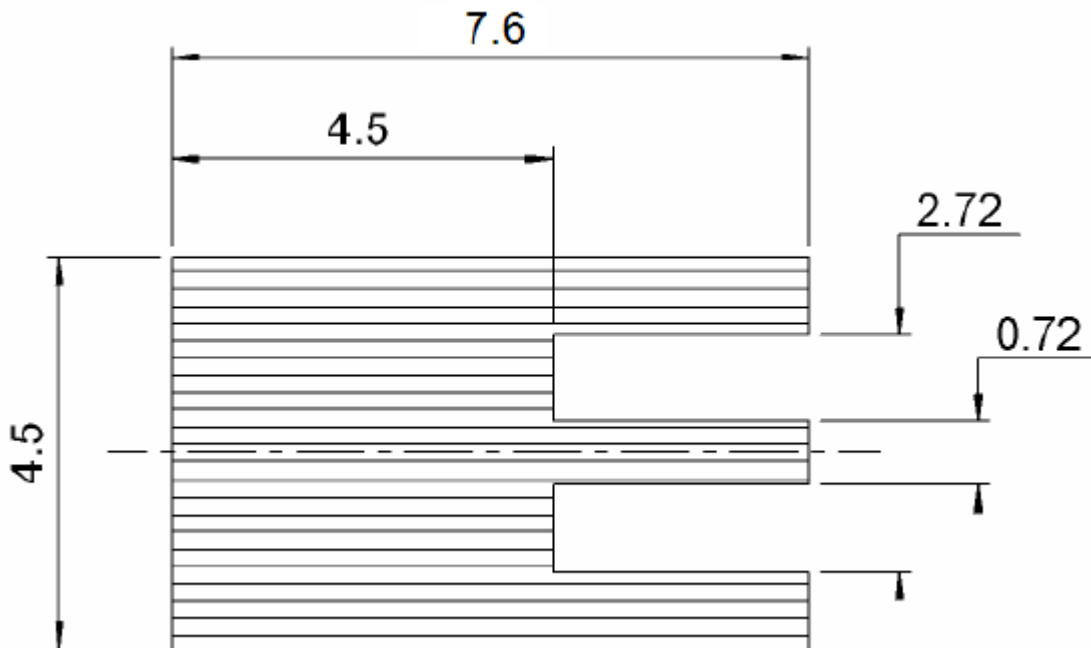

PAGE 5/5	ISSUE 1432B	SERIES ECO MMCX	PART NUMBER R110A422830
----------	-------------	-----------------	-------------------------

